

Minicoil FEP and Q-Series Heat Exchangers

FEATURES

- **For electroless nickel:**
Q-Series tubing in a protective polypropylene or PTFE frame
- **For chrome and other plating:**
FEP* tubing in a protective CPVC or PTFE frame
- **Three compact frame sizes (nominal):**
12 x 12 in., 15 x 15 in., 18 x 18 in.
- **Heat transfer areas from 2.1 ft² (0.195 m²) to 10.0 ft² (0.929 m²)**

DESCRIPTION

AMETEK Minicoil Heat Exchangers made with fluorocarbon resins are used primarily in small metal finishing baths where corrosion is often a problem. The chemically inert, well-known nonstick characteristics of fluoropolymers resist corrosion and fouling, and minimize scale buildup. The inherently high electrical resistance also helps prevent short circuits and stray currents in the plating baths.

AMETEK offers 12 Minicoil Heat Exchanger models designed specifically for plating bath applications.

* FEP Series coils are considered inert to corrosive chemicals. Q-Series coils are inert to corrosive chemicals except for certain concentrated, hot, oxidizing chemicals.

Contact an AMETEK representative for chemical resistance data on your specific application.



Q-SERIES MINICOIL

MINICOILS

NOMINAL SIZE (IN)	TUBES PER UNIT	TUBE OUTSIDE DIAMETER	TUBE WALL THICKNESS
12	1 or 2	0.25 in (6.4 mm)	0.025 in (0.64 mm)
15 and 18	3 or 4	0.312 in (7.9 mm)	0.025 in (0.64 mm)

HEAT TRANSFER AREA

SIZE (IN)	NO. OF TUBES	AREA FT ²	AREA M ²
12	1	2.1	0.195
12	2	4.2	0.39
15	3	4.5	0.42
15	4	6.0	0.56
18	3	7.5	0.70
18	4	10.0	0.93

OPERATING LIMITS

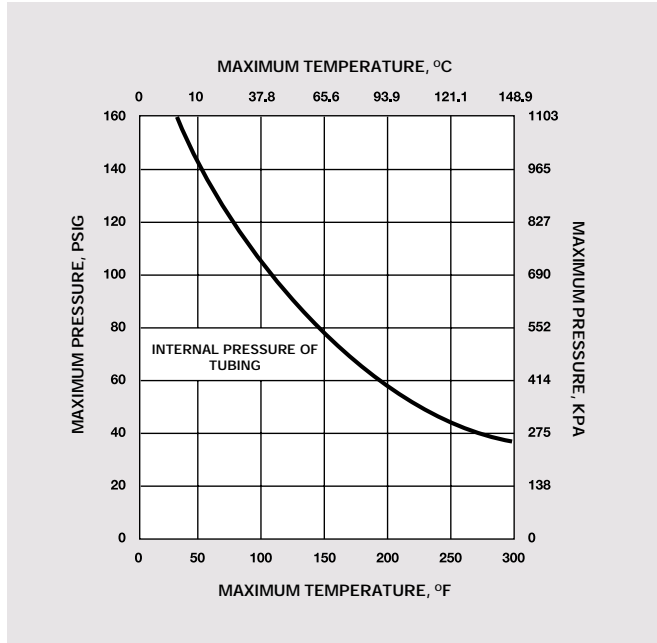

TUBE PRESSURE DROP

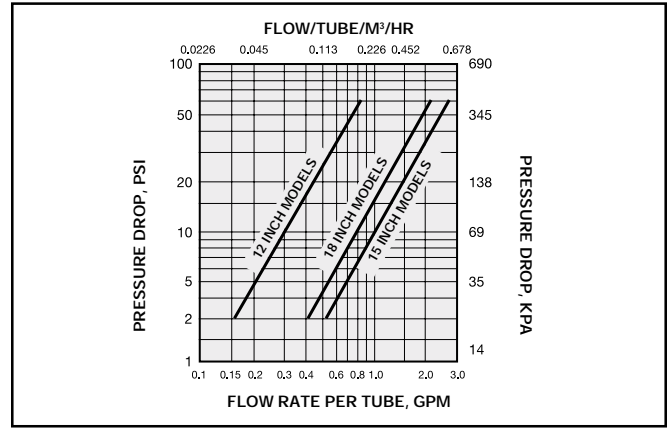

NOMENCLATURE

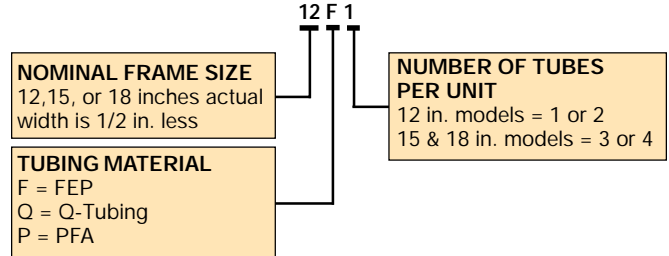

NOTE: Standard Frame for 12 inch is PTFE plate. Standard Frame for 15 and 18 inch is CPVC for FEP tubing, and PP for Q-Tubing.

DIMENSIONS

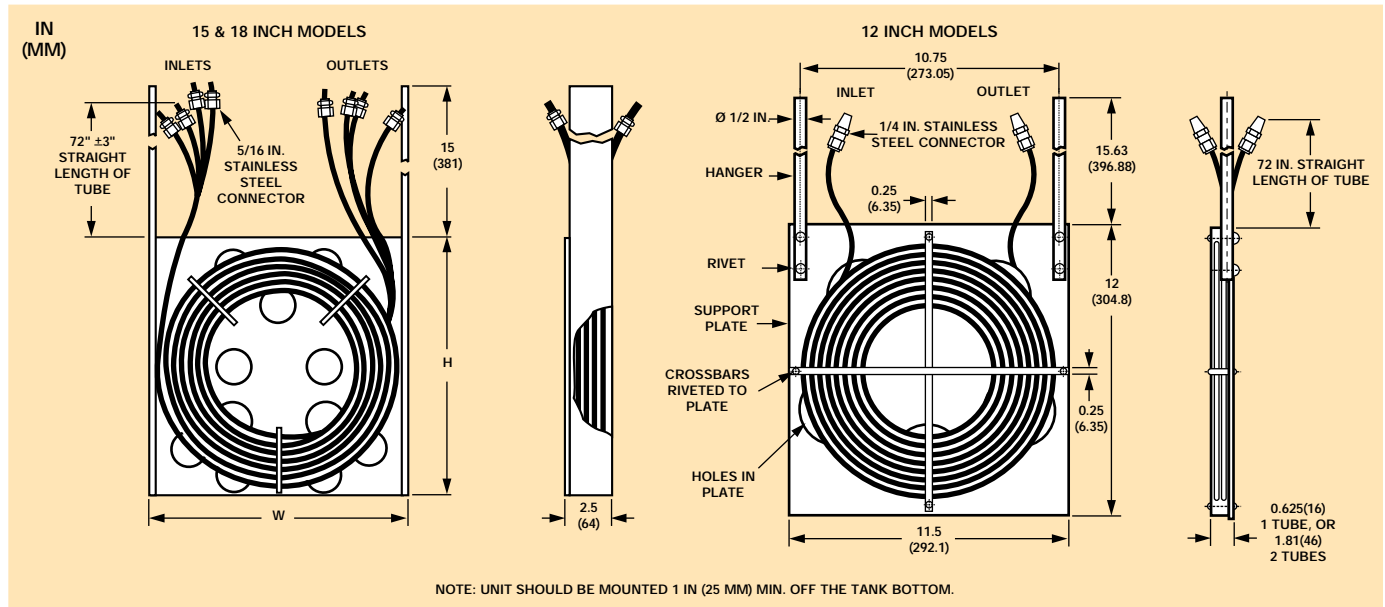

Fluoropolymer resins are generally considered inert to most chemicals. Under certain conditions of pressure and temperature, or combinations of chemicals, fluoropolymer tubing should not be used. Please contact AMETEK for discussion of your specific process to be certain that our products are appropriate for your intended use.

Adequate ventilation should be used where fluoropolymers are heated during tube repairs. Flu-like symptoms may occur from exposure to vapors evolved from fluoropolymers at very high temperatures, up to 800°F or from smoking materials that contain particles of fluoropolymers. Symptoms pass within 48 hours and are the only adverse effects observed in humans to date. Unheated fluoropolymers are essentially inert and are nonirritating to the skin.

This information set forth herein is furnished free of charge and is based on technical data which AMETEK believes to be reliable. It is intended for use by persons having technical skill and at their own discretion and risk. Since conditions of use are outside our control, we make no warranties, express or implied, and assume no liability in connection with your use of this information. Nothing herein is to be taken as a license to operate under or a recommendation to infringe any patents.



900 GREENBANK ROAD, WILMINGTON, DELAWARE 19808 U.S.A.

TEL: (302) 995-0400 • (800) 441-7777 • FAX: (302) 995-0491 • www.ametek.com/haveg • E-mail: info.haveg@ametek.com



© 2002, by AMETEK, Inc. All rights reserved.
 1.5M102A (040020)



Printed in the U.S.A.
 on recycled paper